

TECHNICAL DATA – 1 of 3

Silverline

Uncoated – Eucalypt Core

SCOPE OF USE

A decorative plywood designed for projects where you don't need a structural panel. Ideal for wall and ceiling linings in residential, commercial, or industrial spaces where a premium finish isn't essential. It's also a handy choice for general DIY jobs and craft projects.

LIMITATIONS

Silverline must not be used in exterior settings without full protection, in interior areas prone to moisture, or in any location exposed directly to weather or humidity.

MOISTURE CONTENT

Skape Lining Plywood has an average moisture content of 6–15% at the time of manufacture and will remain within this range when stored and handled correctly. Refer to the Installation Guide for further details.

TECHNICAL PROPERTIES

A decorative plywood with two smooth, light-blond faces. It features one B-grade face and one C-grade face, with no open-face knotholes; minor bird's-eye knots are acceptable on the back. Each panel is sanded to 200 grit and hot-pressed twice for a consistent, refined finish.

Sizes Available	2400 x 1200 9, 12 & 18mm
Species	Betula / Eucalyptus Grandis
Country of Origin	China
Structural Standard	9/12mm - P21 Brace Tested by Scion NZ 2021
Treatment Type	Untreated
Face Grade	BC
Glue Line	Urea Formaldehyde
Emission	AS/NZS 2098.11 E0 - <0.5 mg/L
Certification	N/A
Hazardous Goods Rating	NA
BPIR Class	Class 1
Warranty Period	12 Months Limited & Conditional
Thermal Conductivity	0.138 w/m/K
Density Average	540kg/m ³

TECHNICAL DATA – 2 of 3

Silverline

Uncoated – Eucalypt Core

DIMENSIONAL PROPERTIES

Tolerances:

Length +1.5mm/-1.5mm on the specified nominal value

Width +1.5mm/-1.5mm on the specified nominal value

Thickness ± 0.4 mm on the specified nominal value for sanded grades

Squareness Within <3mm of the length of the longer diagonal

Straightness Within <3mm of the length

Diagonals Below 3mm difference on a 2400 x 1200mm sheet

Nominal Thickness	Number of Plies	Face Thickness Nominal	AVG Mass Per Sheet
mm	#	mm	Kg
9	3	0.3	19.01
12	5	0.3	23.76
18	7	0.3	28.51

Mass has been calculated considering 6 to 15% moisture content and sheet size of 2400x1200 and a density of 540kg/m³

TECHNICAL DATA – 3 of 3

Silverline

Uncoated – Eucalypt Core

BRACING RATINGS

The Amberline and Silverline range of plywood has been P21 Brace Tested by Scion, New Zealand and have been manufactured and tested in accordance with NZS3604:2011. The range is resistant to earthquake and wind loads on timber framed buildings.

For more information on bracing and installation, please refer to our Plywood Bracing Installation Guide.

Thickness (mm)	9mm	12mm
Min Wall Length (mm)	1200	1200
Max Stud Spacing (mm)	600	600
Wind BU/m	109	114
Earthquake BU/m	109	114

Notes: 20 bracing units = 1kN.

* As limited by the serviceability load capacity.

** As limited by the ultimate load capacity.

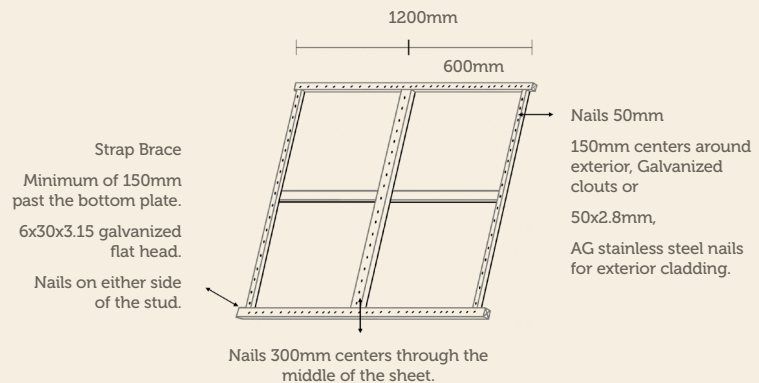

Test Notes:

- Walls were constructed using 90x45 MSG8 studs (600 centres), plates and nogs.
- Straps of 25x0.9mm around the bottom plate at each outside stud and extended a minimum of 150mm past the top of the bottom plate were used with at least 6 timber bracket galvanized 30x3.15mm FH nails on each side of the plate giving 6kN on each side of the stud.
- Tested on a concrete floor with 2 M12 hold down bolts and 50x50x3 galvanized washers on each.
- Tested by Scion, New Zealand, April 2011.

WARRANTY INFORMATION

Skape Limited provides a limited warranty for our Interior Lining Untreated Plywood, ensuring the product is free from manufacturing defects for a period of 12 months from the date of purchase. This warranty covers issues related to material quality and workmanship, provided the plywood is installed and maintained according to standard guidelines. This warranty does not cover damage resulting from improper installation, exposure to moisture, environmental conditions, or misuse. Claims must be submitted with proof of purchase for evaluation.